

STRONG FOR THE BUTCHER TRADE



Electric grinders • (Mixer) Automatic grinders
(Mixer) Angle grinders



K+G WETTER

YOUR ADVANTAGES

Page 4

ELECTRIC GRINDER B 98, 32/100

Compact powerhouse

Page 6

ELECTRIC GRINDER D 114

The professional for hygiene safety

Page 8

**AUTOMATIC GRINDER AND
MIXER AUTOMATIC GRINDER
D 114 + E 130**

Automatically to the best product

Page 10

**ANGLE GRINDER AND
MIXER ANGLE GRINDER
E 130 + G 160**

Grinding in perfection

Page 12

YOUR OPTIONS

Page 14



**BECAUSE
WE UNDERSTAND
OUR CRAFT**



Quality grinders from K+G

Craft means a passion for precision, the highest standards of quality and love for the product - especially in meat processing. Our grinders know exactly what matters in the craft and set new standards in terms of hygiene, safety and ease of use.

BUILT-IN QUALITY

Thanks to their stable design, K+G Wetter grinders are long-lasting partners. Every machine size offers maximum production capacity even in continuous operation and achieves maximum performance with low-noise running. Made of high-grade stainless steel, our grinders are absolutely rustproof and also completely closed all around. No splash water can penetrate and the machines are much easier to clean. This leaves more time for the essentials: the art of the perfect taste.

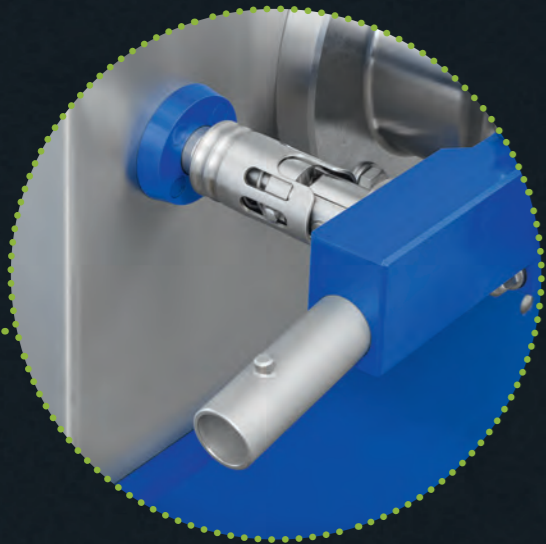

PNEUMATIC SORTING DEVICE

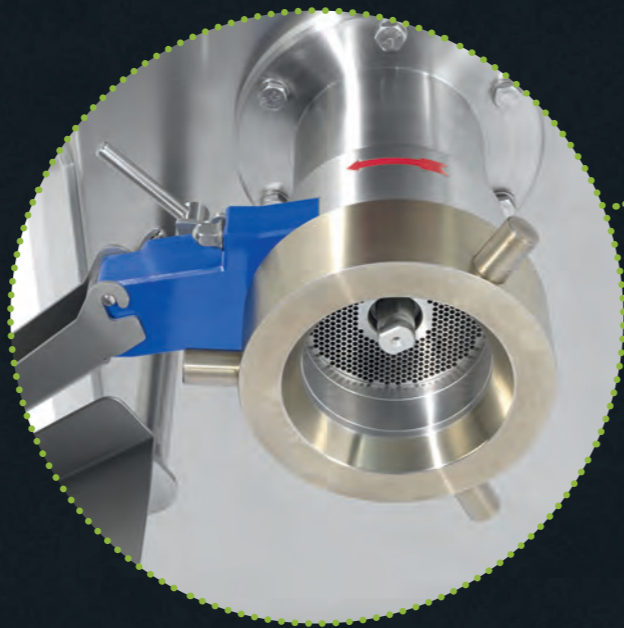

MANUAL SORTING DEVICE

"The K+G machines have become an indispensable part of our production in order to offer fresh, top-quality products on a daily basis. The powerful and high-performance machines are easy to clean – a real must in our company."

Dirk Wunsch, Managing Director of Wunsch's Fleischspezialitäten

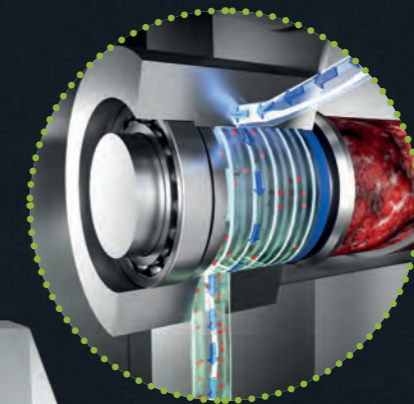

THE FLUSHING CHAMBER

The highest possible safety standard is achieved during daily cleaning.

Sorting device and flushing chamber explained



kgwetter.de/en/machinery/animations

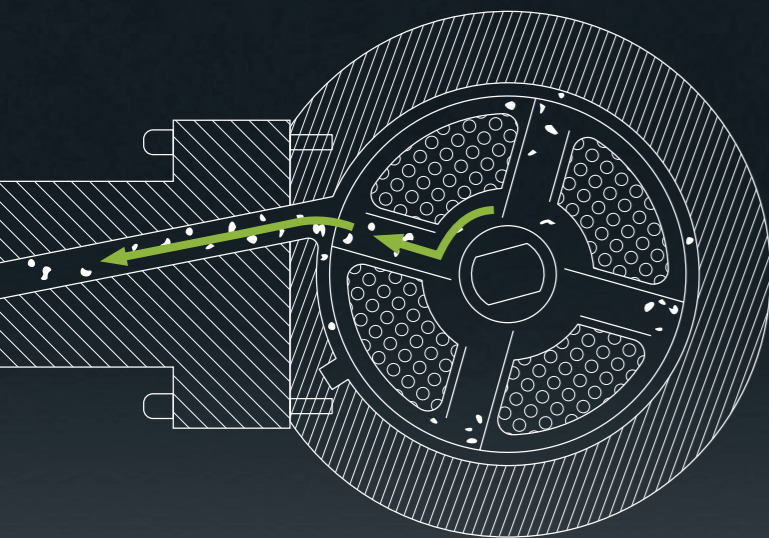
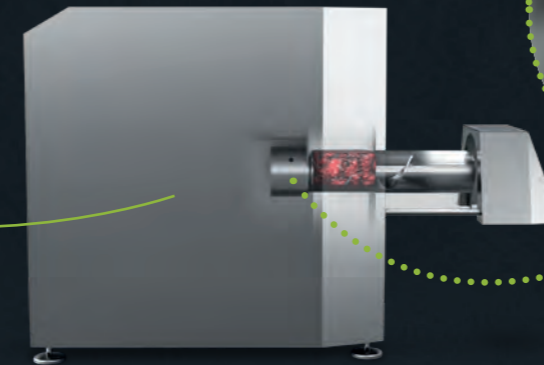

SORTING DEVICE WITH SIDE DISCHARGE

for even more reproducible sorting results. Standard perforated disks in combination with special sorting knives ensure the largest possible product throughput and significantly better sorting results than conventional systems.

EASY ACCESS

practical access to hopper



YOUR ADVANTAGES

- Heavy, stable and robust design for long service life and smooth running of the machines
- Moisture cannot penetrate due to completely enclosed machine housing
- Hand-polished surfaces ensure maximum hygiene during cleaning and allow cleaning liquid to run off without residues
- A flushing chamber in front of each of the feeder and meat worm drives for thorough cleaning of hard-to-reach areas and maximum hygiene
- Easy assembly of all components without tools
- Chain and V-belt tensioners for longer maintenance intervals, less wear on the machine and higher operational reliability
- Special K+G twin-worm principle for uniform product flow

- and constant pressure in the cutting set for gentle processing of the ground meat
- Optimum hopper design for uniform product transport, which prevents bridging
- Reverse rotation of feeder worm during mixing process allows mixing of products from the bottom of the grinder hopper as well
- Easy gripping of even larger pieces of meat resulting in a continuous production process due to the greater pitch of the feeder worm
- Delayed start-up of the meat worm to prevent dry starting of the cutting set and to minimise wear
- Ejecting device for easy and tool-free removal of meat worm and cutting set

- Robust membrane keyboard with self-explanatory control panel for intuitive control of the machines
- Maximum safety due to electrically secured overflow protection, which prevents interference with the cutting set or the end-hole plate
- The machines stop automatically when the safety grids and rocker switches are actuated for maximum safety
- Fast delivery of spare parts in case of service and personal support on site



MEMBRANE KEYBOARD

for intuitive operation

CUTTING SYSTEMS

Two different variants (Unger/Enterprise) for optimal results depending on product

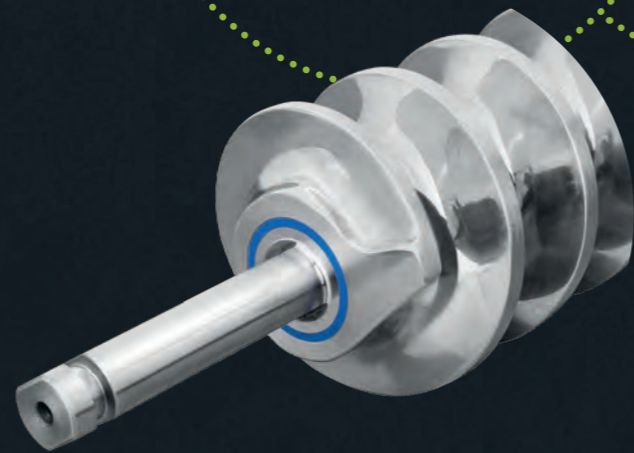

ELECTRIC GRINDER B 98, 32/100

Compact powerhouse

Easy handling and strong performance are clearly the focus of the K+G entry-level model. With a hopper volume of 35 litres, it effortlessly processes 15 kilograms of meat and other products per minute. Our powerhouse also demonstrates efficiency during cleaning: A quick-action connector ensures that the housing of the worm can be removed in no time at all.

TWO CUTTING SYSTEMS FOR INDIVIDUAL USE

You have the choice of cutting system: A particularly gentle chopping process is provided by the Unger B 98 cutting system (EW B 98 mm). It consists of pre-cutters, two knives, four hole plates of different sizes and two spacer rings. The Enterprise cutting system (EW 32/100 mm), consisting of a four-bladed cross-shaped knife and the end hole plate, is preferred for minced meat production. Maximum flexibility for individual use.

NEW! INNOVATIVE CUTTER PIN

- highly durable connection
- special seal made of particularly durable material
- quick, easy and inexpensive replacement of the cutter pin in the event of damage using standard tools
- time-saving and hygienically reliable cleaning thanks to the particularly smooth surface finish
- standard on all grinders and mixer grinders

HOUSING OF THE WORM

Easily removable housing of the worm – can be stored separately in a cool place if required

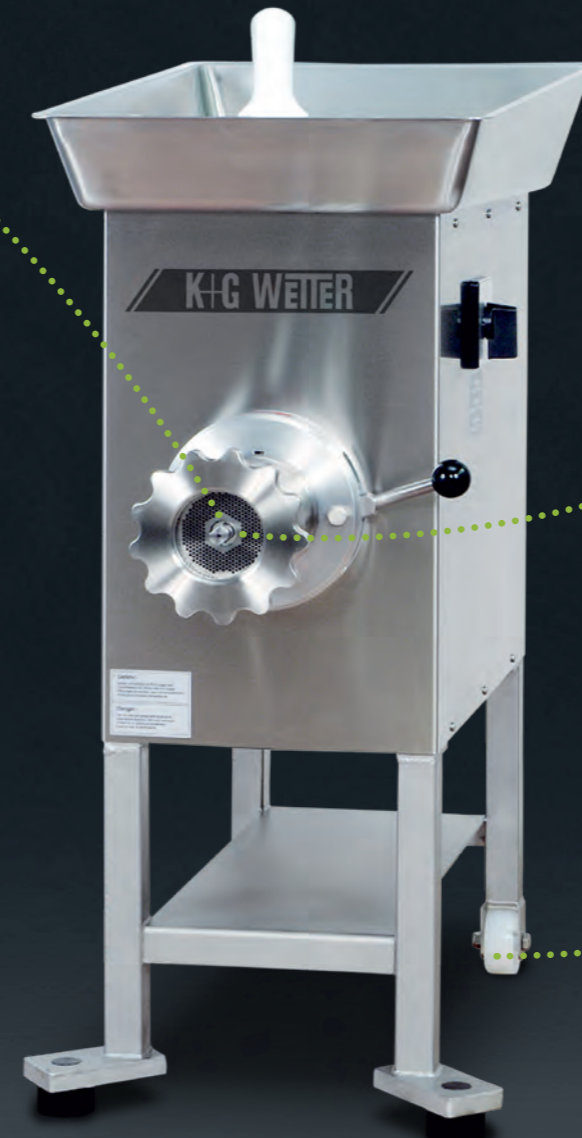

ROLLERS

On two stands for easy movement of machine and maximum flexibility

DIMENSIONS

Electric grinder EW B 98, 32 / 100

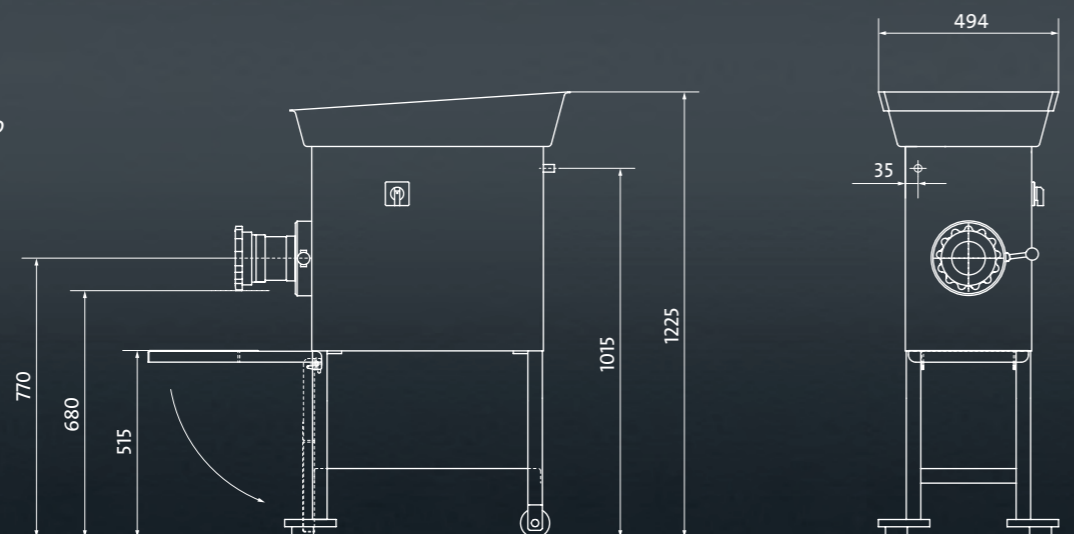

All dimensions in mm

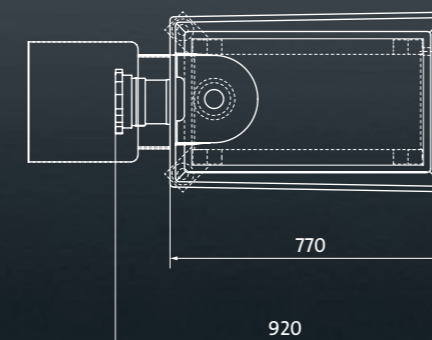

TECHNICAL DATA

	Electric grinder EW B 98 with Unger cutting system	Electric grinder EW 32/100 with Enterprise cutting system
Type	640	640
Operating voltage	400V / 50 Hz	400V / 50 Hz
Rated connected load	3 kW	3 kW
Rated current	5.3 A	5.3 A
Back-up fuse – supplied by customer	16 A gL/gG	16 A gL/gG
Fresh meat processing capacity	10–15 kg/min.	10–15 kg/min.
Bowl / Hopper capacity	35 l	35 l
Noise level at no load	approx. 36 dBA	approx. 36 dBA
Weight	108 kg	108 kg

All equipment options of the EW B 98, 32 / 100 can be found on pages 14 and 15 in this brochure.

ELECTRIC GRINDER D 114

The professional for hygiene safety

Our stuffing grinder excels with high performance and smooth running – for a perfect and homogeneous cutting pattern. In addition, it scores points with a flushing connection that makes it easy to clean the inside of the machine as well, thus ensuring optimal hygiene. Cleaning is also particularly safe thanks to a removable hand guard above the filling shaft: If this is removed, the machines stop automatically and thus prevent injuries.

EASY, QUICK FILLING

A further advantage: The large filling opening makes filling not only easier, but also faster – for short throughput times, efficient cleaning and high yield.

DIMENSIONS

Electric grinder EW D 114

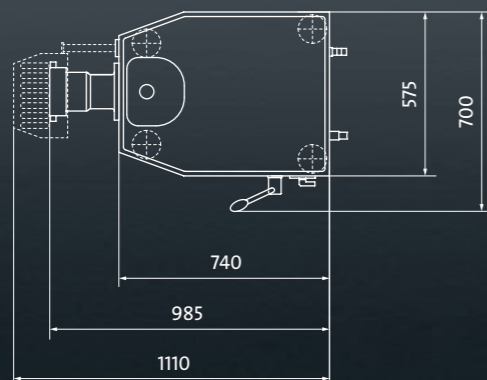

All dimensions in mm

SORTING DEVICE

Manual version scores with simple, tool-free installation and removal, thus easier cleaning, immediately visible and, if required, directly readjustable sorting result (pneumatic sorting device available for WW E 130 and G 160)



NEW! CLEARCUT – CLEAN CUTTING AND PERFECT SORTING

- available from a cutting set diameter of 114 mm
- optimises the cutting pattern thanks to the new cutting geometry
- reliably sorts out unwanted hard particles such as cartilage, small bone parts or tendons and separates them selectively
- guarantees permanently good results thanks to a long service life
- only the sorting knife in the cutting set is exchanged for a standard knife, a special cutting set is unnecessary
- very good red-white distribution

HAND GUARD

With large distance to the floor for easy insertion of even large pieces of material

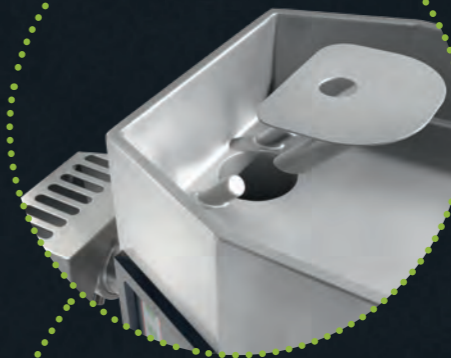

All equipment options of the EW D 114 can be found on pages 14 and 15 in this brochure.



MEMBRANE KEYBOARD

Or hand switch (depending on equipment) for intuitive and easy operation

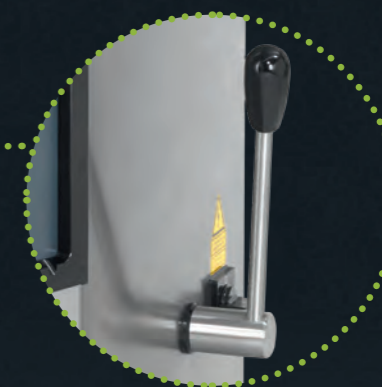

EJECTING DEVICE

Mechanically guarantees easy disassembly of the meat worm and cutting set, even if there is product residue in the housing

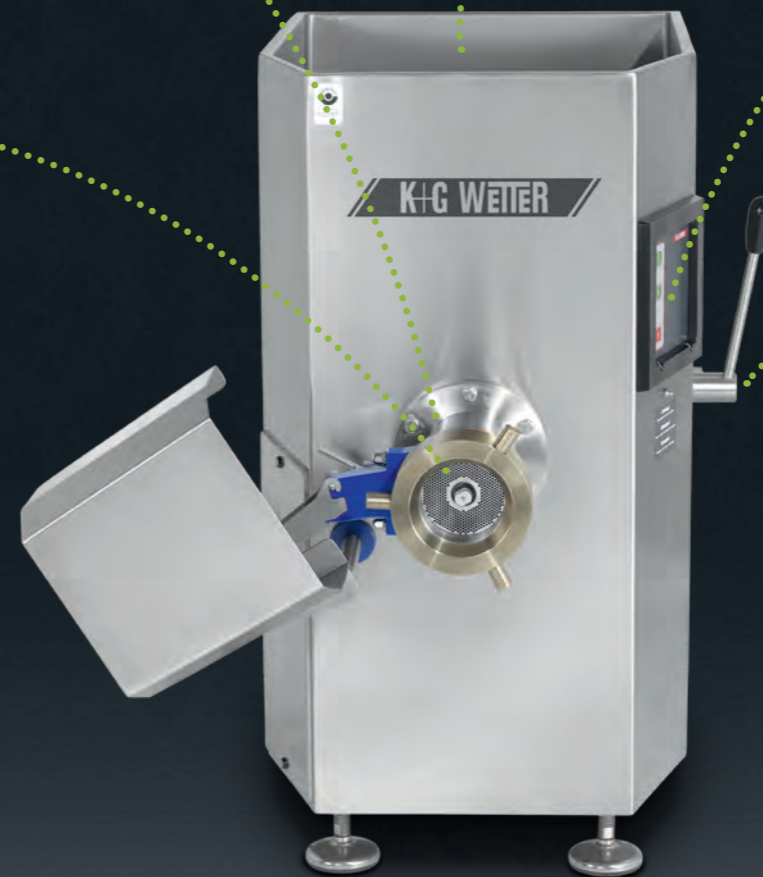

TECHNICAL DATA

	Electric grinder EW D 114 Hand switch single speed / two-speed	Electric grinder EW D 114 Membrane keyboard single speed / two-speed
Type	403	403
Operating voltage	400V / 50 Hz	400V / 50 Hz
Rated connected load / reinforced	5.5 kW / 6 kW	5.5 kW / 6 kW
Rated current / reinforced	11.4 A / 13.3 A	11.4 A / 13.3 A
Back-up fuse supplied by customer / reinforced	16 A gL/gG / 20 A gL/gG	16 A gL/gG / 20 A gL/gG
Fresh meat processing capacity	Up to 25 kg/min.	Up to 25 kg/min.
Bowl / Hopper capacity	55 l	55 l
Water pressure flushing connector	Max. 1 bar	Max. 1 bar
Noise level at no load	approx. 64 dBA	approx. 64 dBA
Weight	300 kg	300 kg

AUTOMATIC GRINDER AND MIXER AUTOMATIC GRINDER D 114 + E 130

Automatically to the best product

Our automatic grinders work completely autonomously - it couldn't be easier. The feeder and meat worm combine to perform real teamwork for perfect processing. The special twin-worm principle of K+G Wetter ensures that the filling flow towards the cutting set remains constant and does not break off. At the same time, the different pitches of the worms ensure optimum product flow with the best cutting result and guarantee only a slight temperature increase of the material.

FLEXIBLY MIXED IN FOR THE PERFECT RESULT

A mixing shaft located above the feeder worm comes into play for particularly intensive and gentle mixing. The reverse running feeder worm supports the effective mixing paddle in that the product to be mixed is repeatedly transported from the bottom of the hopper into the mixing circuit. "Spice clumps" are a thing of the past and the development of "dead spaces" is prevented.

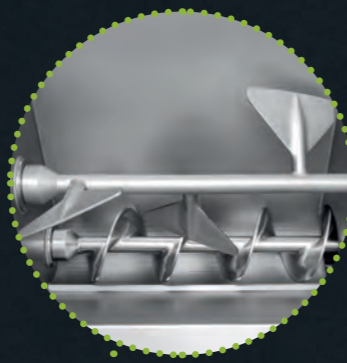

MIXING SHAFT

For optimum, homogeneous mixing (in combination with the reverse running feeder worm). Mixing shaft and feeder worm can be easily removed for cleaning.

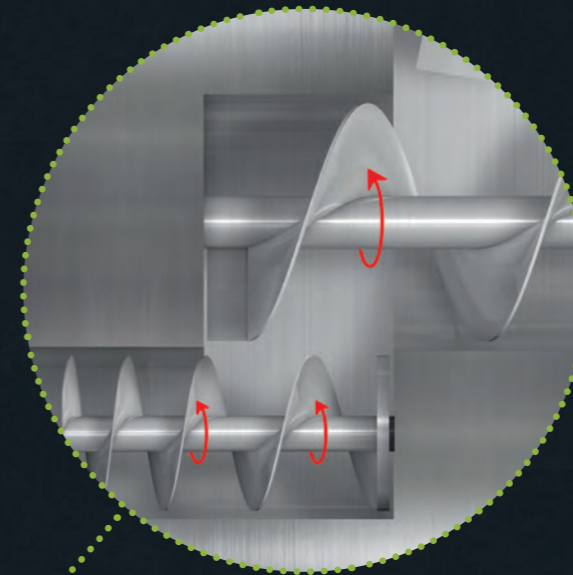

TWIN-WORM PRINCIPLE

With perfectly coordinated speeds for gentle material feeding, a clear cutting pattern and best cutting results

All equipment options of the AW and MAW D 114 + E 130 can be found on pages 14 and 15 in this brochure.

TECHNICAL DATA

	Automatic grinder AW D 114	Mixer automatic grinder MAW D 114	Automatic grinder AW E 130	Mixer automatic grinder MAW E 130
Type	412	409	404	417
Operating voltage	400V / 50 Hz	400V / 50 Hz	400V / 50 Hz	400V / 50 Hz
Rated connected load	9 kW	9 kW	9 kW	9 kW
Rated current	20 A	20 A	20 A	20 A
Back-up fuse – supplied by customer	25 A gL/gG	25 A gL/gG	25 A gL/gG	25 A gL/gG
Fresh meat processing capacity	Up to 50 kg/min.	Up to 50 kg/min.	Up to 60 kg/min.	Up to 60 kg/min.
Bowl / Hopper capacity	110 l	110 l	110 l	110 l
Mixing capacity	–	approx. 70 kg	–	approx. 70 kg
Water pressure flushing connector	Max. 1 bar	Max. 1 bar	Max. 1 bar	Max. 1 bar
Noise level at no load	approx. 66 dBA	approx. 68 dBA	approx. 66 dBA	approx. 68 dBA
Weight	570 kg	590 kg	570 kg	590 kg

DIMENSIONS

Automatic grinder
and mixer automatic grinder
AW D 114 / MAW D 114

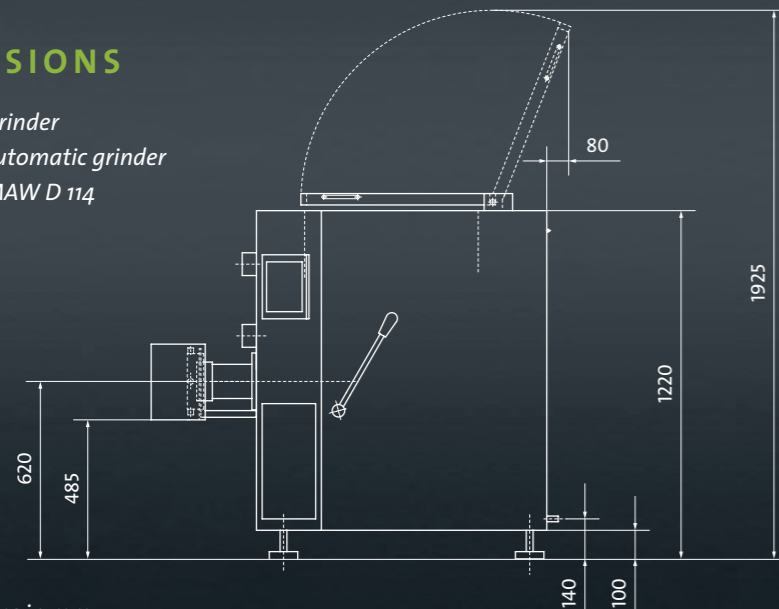

All dimensions in mm

DIMENSIONS

Automatic grinder and
mixer automatic grinder
AW E 130 / MAW E 130

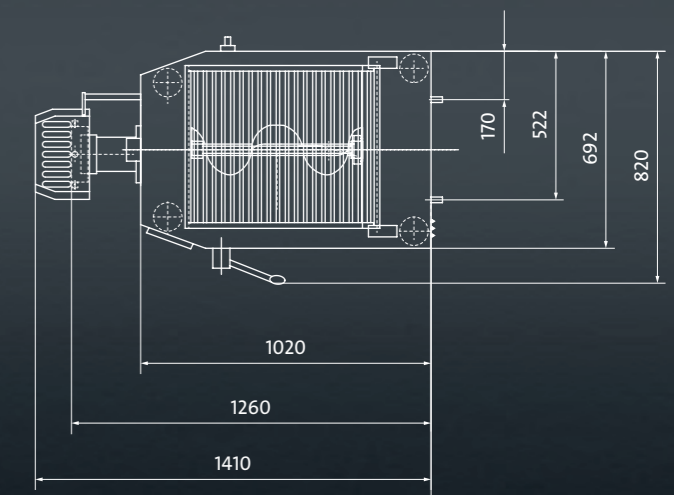
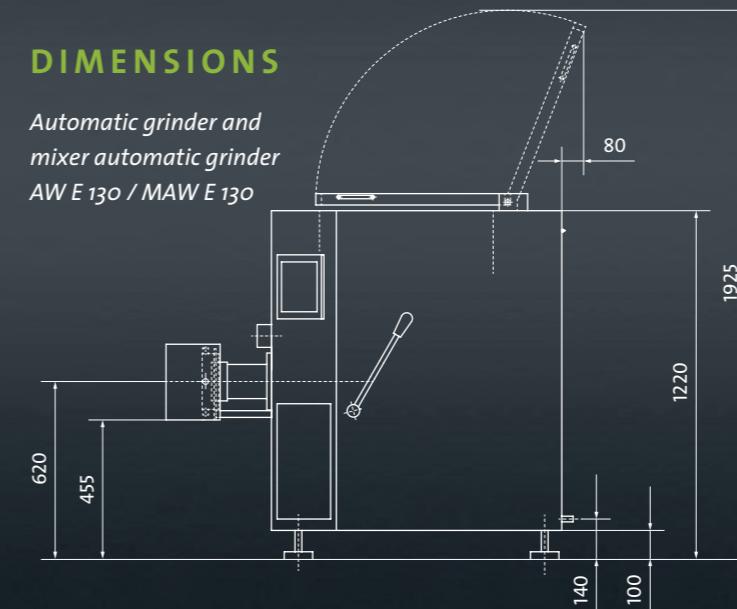

ANGLE GRINDER AND MIXER ANGLE GRINDER E 130 + G 160

Grinding in perfection

To achieve more in the craft sector, you need machines that can do more. Our angle grinders and mixer angle grinders E 130 and G 160 are perfected thanks to the advanced "Easy Access". Practical access to the grinder hopper is not only quick and efficient, but offers ergonomic advantages as well – because it makes the removal of the mixing shaft and feeder worm much more convenient. There is enough physical exertion involved in the day-to-day operation. So why not simply make the work easier?

A MACHINE THAT ADAPTS TO YOU.

The powerful grinder offers you more flexibility by fitting and removing the mixing shaft in seconds. If required, the grinder becomes a mixer angle grinder in a flash. The feeder worm underneath the mixing shaft can be removed just as quickly and easily, making it child's play to clean the machine and its components. In addition, visual inspection of the cleaning process can be carried out effortlessly and safely. The ultimate in grinding in perfection.

DIMENSIONS

Angle grinder and mixer angle grinder WW E 130 / MWW E 130 without loading device

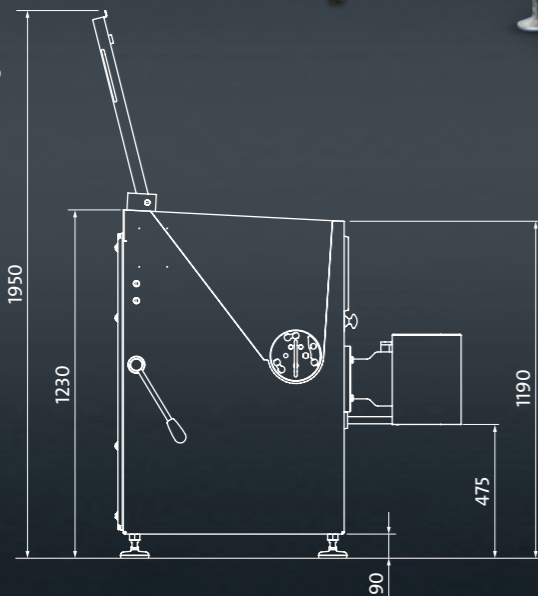

All dimensions in mm



EASY ACCESS

Practical access to hopper for easy fitting and removal of mixing shaft and feeder worm as well as extremely easy cleaning



BAYONET LOCK NUT

For quick clamping or changing of the cutting set

TECHNICAL DATA

	Angle grinder WW E 130	Angle grinder WW E 130	Mixer angle grinder MWW E 130	Mixer angle grinder MWW E 130	Mixer angle grinder MWW G 160
Type	436	442	437	443	449
Operating voltage	400V / 50 Hz	400V / 50 Hz	400V / 50 Hz	400V / 50 Hz	400V / 50 Hz
Rated connected load / reinforced	16 kW / 19 kW	16 kW / 19 kW	16 kW / 19 kW	16 kW / 19 kW	19.4 kW / 23.4 kW
Rated current / reinforced	35 A / 40 A	35 A / 40 A	35 A / 40 A	35 A / 40 A	40 A / 54 A
Back-up fuse supplied by customer / reinforced	35 A gL/gG / 50 A gL/gG	35 A gL/gG / 50 A gL/gG	35 A gL/gG / 50 A gL/gG	35 A gL/gG / 50 A gL/gG	50 A gL/gG / 63 A gL/gG
Fresh meat processing capacity	Up to 65 kg/min.	Up to 65 kg/min.	Up to 65 kg/min.	Up to 65 kg/min.	Up to 83 kg/min.
Processing capacity Grinding pre-ground frozen meat min. -8 °C	Up to 20 kg/min.	Up to 20 kg/min.	Up to 20 kg/min.	Up to 20 kg/min.	Up to 25 kg/min.
Bowl / Hopper capacity	185 l	355 l	185 l	355 l	355 l
Mixing capacity	-	-	approx. 135 kg	approx. 190 kg	approx. 190 kg
Water pressure flushing connector	Max. 1 bar	Max. 1 bar	Max. 1 bar	Max. 1 bar	Max. 1 bar
Noise level at no load	approx. 71 dBA	approx. 71 dBA	approx. 71 dBA	approx. 71 dBA	approx. 71 dBA
Weight	810 kg	970 kg	840 kg	1010 kg	1060 kg

DIMENSIONS

Angle grinder and mixer angle grinder WW E 130 / MWW E 130 with pilon loading device

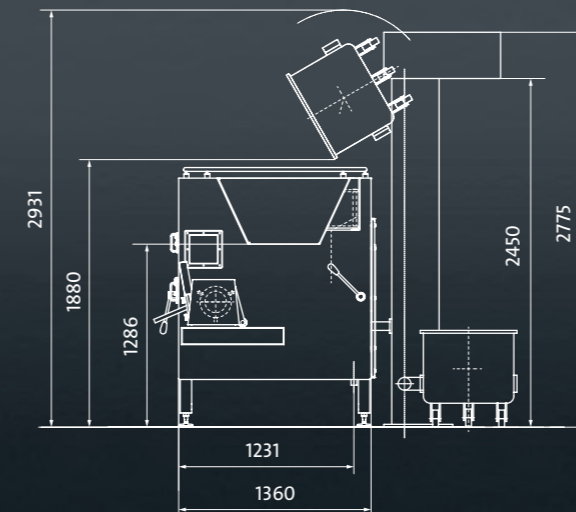

DIMENSIONS

Mixer angle grinder MWW E 130 / MWW G 160 with hydraulic loading device

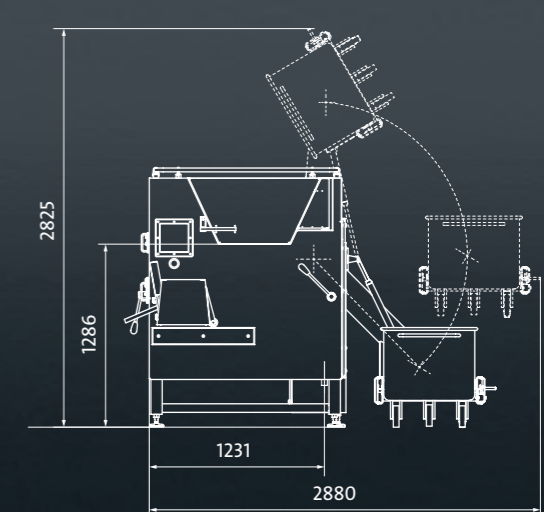

YOUR OPTIONS

The highest quality standards are already included in the basic equipment of K+G Wetter machines. For the greatest possible flexibility, additional clever options can be added to all machines. We are happy to help you configure your customised machine to suit your requirements.



	EW B 98 Type 640	EW 32/100 Type 640	EW D 114 Hand switch Type 403	EW D 114 Membrane keyboard Type 403	AW D 114 Type 412		MAW D 114 Type 409	AW E 130 Type 404	MAW E 130 Type 417	WW E 130 Type 436	WW E 130 Type 442	MWW E 130 Type 437	MWW E 130 Type 443	MWW G 160 Type 449
Hopper and outer surface of stainless steel	✓	✓	✓	✓	✓		✓	✓	✓	✓	✓	✓	✓	✓
Safety grid electrically locked via hopper	x	x	x	x	✓		✓	✓	✓	✓	x	✓	x	x
Switch frame with safety switches around all sides of the hopper rim	x	x	x	x	x		x	x	x	x	✓	x	✓	✓
Easy Access (easy access to interior of the hopper)	x	x	x	x	x		x	x	x	x	✓	x	✓	✓
Braking device for meat worm drive	x	x	✓	✓	✓		✓	✓	✓	✓	✓	✓	✓	✓
Machine closed on all sides	✓	✓	✓	✓	✓		✓	✓	✓	✓	✓	✓	✓	✓
Rustproof, sealed drive shaft supported on ball bearings	✓	✓	✓	✓	✓		✓	✓	✓	✓	✓	✓	✓	✓
Meat worm and housing of the worm in stainless steel	✓	✓	✓	✓	✓		✓	✓	✓	✓	✓	✓	✓	✓
Stainless steel feeder worm, removable for cleaning	x	x	x	x	✓		✓	✓	✓	✓	✓	✓	✓	✓
Stainless steel mixing shaft, removable for cleaning	x	x	x	x	x		✓	x	✓	x	x	✓	✓	✓
Stainless steel lock nut	✓	✓	✓	✓	✓		✓	✓	✓	✓	✓	✓	✓	✓
Unger cutting set	✓	x	✓	✓	✓		✓	✓	✓	✓	✓	✓	✓	✓
Enterprise cutting set	x	✓	x	x	x		x	x	x	x	x	x	x	x
Ejecting device for worm and cutting set	x	x	✓	✓	✓		✓	✓	✓	✓	✓	✓	✓	✓
Electrically monitored discharge protector	x	x	x	optional	optional		optional	✓	✓	✓	✓	✓	✓	✓
Hand switch	✓	✓	✓	x	x		x	x	x	x	x	x	x	x
Membrane keyboard	x	x	x	✓	✓		✓	✓	✓	✓	✓	✓	✓	✓
Meat worm drive2-speed	x	x	optional	optional	✓		✓	✓	✓	✓	✓	✓	✓	✓
Meat worm drive2-speed, reinforced	x	x	x	x	x		x	x	x	optional	optional	optional	optional	optional
Manual sorting device	x	x	optional	optional	optional		optional	optional	optional	optional	optional	optional	optional	optional
Pneumatic sorting device	x	x	x	x	x		x	x	x	optional	optional	optional	optional	optional
Bayonet lock nut	x	x	x	x	✓		✓	optional	optional	optional	optional	optional	optional	optional
Pre-selectable mixing time	x	x	x	x	x		optional	x	optional	x	x	optional	optional	optional
Reverse running meat worm (briefly)	x	x	x	x	x		x	x	x	optional	optional	optional	optional	optional
Supporting device of the pre-cutter	x	x	x	x	x		x	x	x	x	x	x	x	optional
Ejecting device for worm and cutting set activated hydraulically, only hydraulic with loading device	x	x	x	x	x		x	x	x	x	optional	x	optional	optional
Hydraulic loading device, flanged to machine base	x	x	x	x	x		x	x	x	x	optional	x	optional	optional
Pilon loading device	x	x	x	x	x		x	x	x	x	optional	x	optional	optional
Cleaning and transport trolley	optional	optional	optional	optional	optional		optional	optional	optional	optional	optional	optional	optional	optional



WE MAKE IT EASY FOR YOU!

.....
That is our requirement.

We have been manufacturing high-quality and reliable machines for meat processing for 25 years. We want one thing above all: to make daily work easier. Our experts are therefore constantly working on new solutions that make our machines even better for you. We also ensure their well-known quality through the careful assembly of the individual components, where our employees personally lend a hand in the details. From the surface to the knife head: K+G Wetter machines are 100 percent "Made in Germany".

We are there where you need us - worldwide. We place particular emphasis on reliability and stability. Not only for our machines, but also in partnerships. We are always personally available for you and your questions - and also ready to help when you need us. You have our word.

WE TACKLE IT: FOR THE BUTCHER TRADE. FOR YOUR SUCCESS.

See for yourself. Give us a call or come by directly. Together we will find the exact solution that completely adapts to your individual requirements and operating processes. We look forward to meeting you!



K+G WETTER GmbH
Goldbergstrasse 21
35216 Biedenkopf-Breidenstein

Tel. +49 (0) 64 61 / 98 40 - 0
Fax +49 (0) 64 61 / 98 40 - 25

info@kgwetter.de
www.kgwetter.de