

# COMPACT TOP-CLASS DEVICES FOR FIRST-CLASS RESULTS



Bowl cutters SM 33 L and 45 L,  
bowl cutter twin 45 L / D114



**K+G WETTER**

**K+G WETTER**

WHY TO CHOOSE THE BOWL CUTTER  
FROM K+G WETTER

Page 5

BOWL CUTTER SM 33 L

*Small batches, great performance*

Page 10

BOWL CUTTER SM 45 L

*Flexible in motion*

Page 12

BOWL CUTTER TWIN 45 L / D114

*Cutter and grinder in one machine*

Page 14



**"From trade to industry, our technology makes meat processing easier. Because even in the smallest details, we value the bigger picture."**

Andreas Wetter, Managing Director K + G Wetter GmbH



## WHY TO CHOOSE THE BOWL CUTTER FROM K+G WETTER

Bowl cutter from K+G Wetter

Good taste knows no compromises – especially in food processing. That's why even the smallest K+G Wetter bowl cutters contain our cumulative experience, which guarantees you one thing: the highest level of quality and hygiene. Right from the beginning.

### ENGINEERING MEETS WORKMANSHIP

As a world-famous brand for high-quality meat processing machines, we know what is important in the butcher trade. Because this is where our roots lie. Discover the difference. And all the little details that will make your work easier. For your increased safety and friction-free processes that pay off immediately. For you. And your customers.



## 5 CLEAR ARGUMENTS FOR YOUR SUCCESS

What our solutions offer – and can bring to you

### 1 ROBUST AND CLEVER CONSTRUCTION

**SOLID CONSTRUCTION FOR DURABILITY AND LONGEVITY:**

completely enclosed machine body – 100% covered with stainless steel: keeps the interior clean

**VIBRATION-REDUCING FEET:**

allow an optimal alignment of the cutter and also significantly reduce vibrations

**CLOSED MACHINE BODY ON THE UNDERSIDE DUE TO BASE PLATE:**

prevents the penetration of material

**SWITCH CABINET IN THE MACHINE:**

saves space and is ready for direct connection, no further cabling or assembly necessary

**CUTTER AND GRINDER IN ONE MACHINE:**

for efficient working in confined spaces (bowl cutter twin)

### 2 MAXIMUM HYGIENE

**BEVELLED STAINLESS STEEL SURFACES:**

allow cleaning water to flow off reliably

**HAND-POLISHED SURFACES:**

easy to clean thoroughly, no hold for adhesions thanks to surfaces polished to the utmost smoothness

**CLEVER DESIGN FOR EASY HANDLING:**

knife heads can be completely removed as a unit or dismantled individually. For easy cleaning.

**Robust machine base**

for low-vibration, quiet running and long machine service life

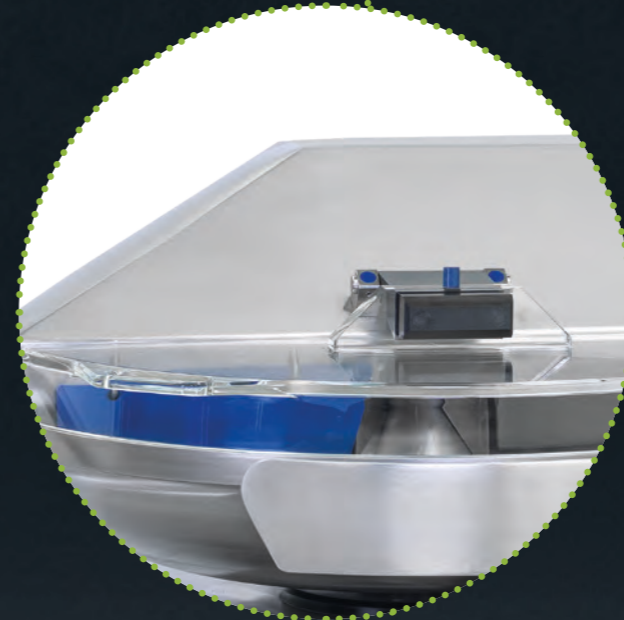

**Inclined surfaces made from stainless steel**

so that cleaning water runs off reliably

### 3 EASY WORKING

**TOUCHPANEL:**

intuitive operation and easy to clean (from SM 45 L)

**PRECISE TEMPERATURE MEASUREMENT:**

for accurate measurement results even with small filling quantities

**MANUAL SORTING DEVICE:**

tool-free installation and removal, thus ensuring easier cleaning, and an immediately visible and adjustable sorting result as required (grinder on bowl cutter twin)



**Emergency stop button**

for emergency braking and maximum safety

## 4 EFFICIENT PROCESSES AND MAXIMUM FLEXIBILITY

### 3 DIFFERENT KNIFE TYPES:

universal, raw sausage and fine meat knives as perfectly coordinated cutting systems for different types of sausage meat and products

### VARIABLE KNIFE SPEEDS (FOR STL):

optimal adaptation of bowl and knife speed to the respective product

### DRIVE OPTIONALLY T2M-R OR STL (FOR SM 45 L):

easy to operate via intuitive touch panel, digital displays provide information about product temperature, knife speed, bowl rounds, and running time

Standard knife head with six serrated knives, universally applicable

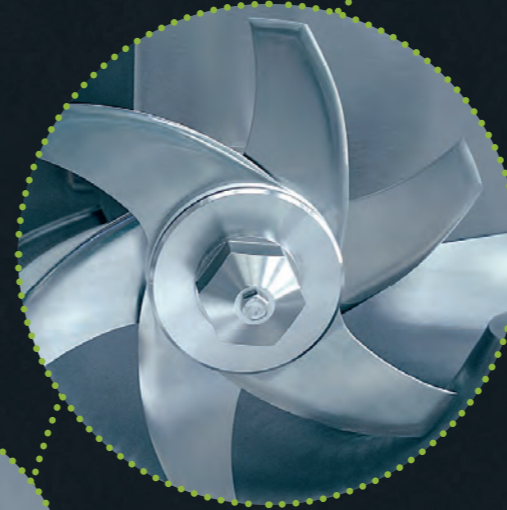
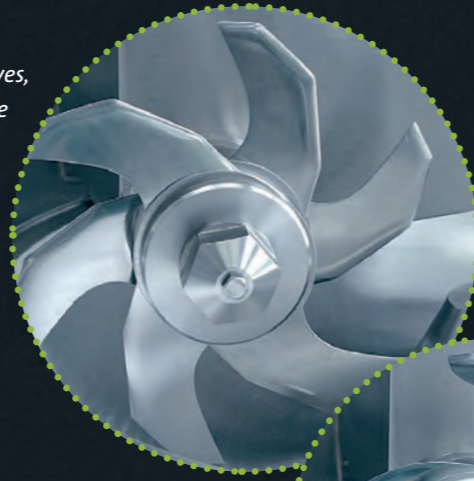

Fine meat knife head with six knives, for extremely fine cooked sausage meat and high-speed bowl cutters

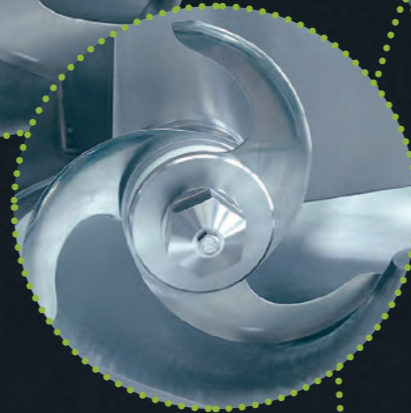

Raw sausage knife head with three sickle knives, ideal for raw sausage meat

### 3 different knife types

for the perfect cut under the most challenging conditions

T2 (SM 33 L)	T2M-R (SM 45 L, bowl cutter twin 45 L / D114)	STL (SM 45 L)
<ul style="list-style-type: none"> <li>– 2 speeds each for cutting</li> <li>– 2-speed bowl drive</li> </ul>	<ul style="list-style-type: none"> <li>– simple and robust technology</li> <li>– 2 speeds each for cutting and mixing (forwards and backwards)</li> <li>– 2-speed bowl drive</li> <li>– standard temperature switch-off</li> <li>– optional: limit switch for bowl rounds and time</li> </ul>	<ul style="list-style-type: none"> <li>– infinitely variable knife shaft: 40-4400 rpm</li> <li>– 2-stage mixing speed</li> <li>– up to 6 forward and 2 reverse gears can be stored</li> <li>– forward and reverse running speed alternatively freely selectable</li> <li>– standard limit switch for temperature, bowl rounds and time</li> </ul>



## 5 SAFETY

### LABYRINTH SEALING DISC ON THE KNIFE SHAFT:

reliably protects the knife shaft bearings by preventing material from penetrating – for trouble-free operation even at maximum speeds

### SEALING WITH WAVE CONSTRUCTION ON THE MASCHINE DOOR:

cleaning water cannot get into the machine. The water stream is interrupted by the seals' wave profile and thus reliably prevents penetration.

### HAND GUARD:

at a large distance from the ground for the safe insertion even of large pieces of material (bowl cutter twin)

### EMERGENCY STOP SWITCH:

brings knife and bowl to a standstill in no time at all

### MADE IN GERMANY QUALITY:

worthwhile investment due to long service life, high failsafe performance, and reliable technology

### Labyrinth sealing disc

for maximum protection of the knife shaft bearing

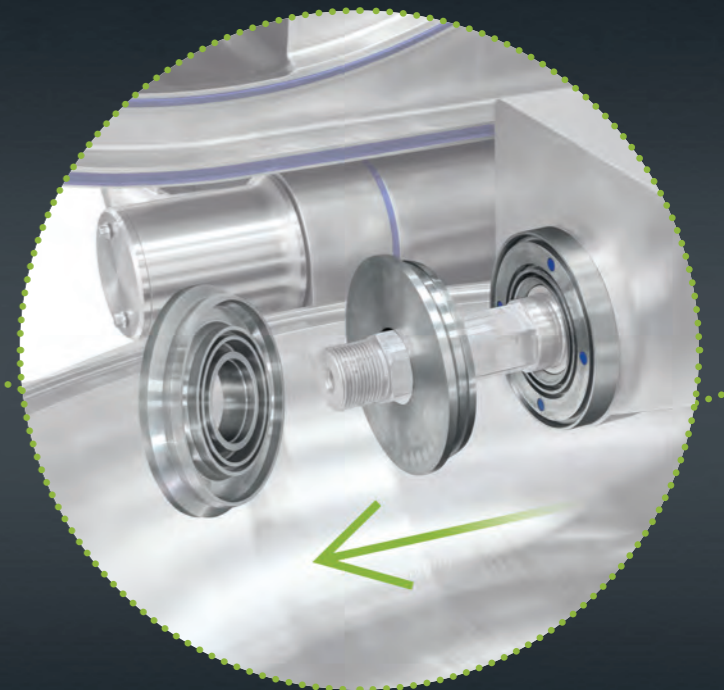

# BOWL CUTTER SM 33 L

Small batches, great performance

Do you produce in manageable quantities or like to try out new recipes? Then the smallest of our trade cutters is perfect for you. You get maximum quality even with small batch sizes – and you can experiment as you wish until the mix is right.

## STABLE BASE

Even our entry-level model has a robust machine base that is stainless-steel-clad on all sides. Even at maximum speeds, your bowl cutter will remain stable and impress with its quiet, low-vibration operation. The seamlessly welded base plate also reliably prevents material from penetrating and, together with other features, ensures maximum hygiene.

## DIMENSIONS

Bowl cutter SM 33 L

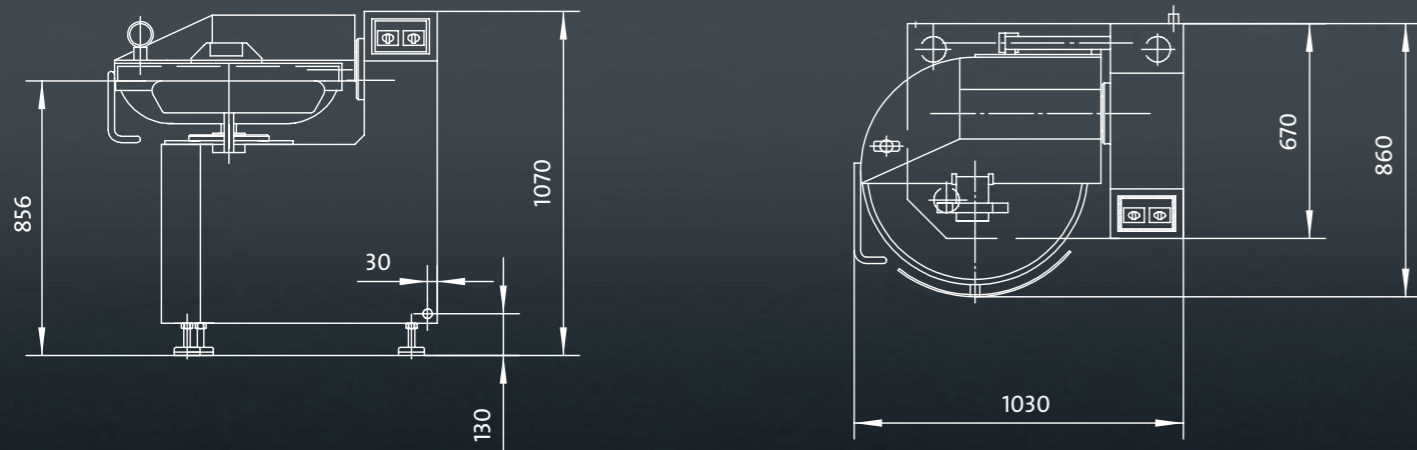

All dimensions in mm



## VIBRATION-REDUCING FEET

for the optimal height and inclination orientation of the machines and quiet, low-vibration running

## TECHNICAL DATA

		SM 33 T2	
Type		425	
Version		Standard	reinforced drive
Electrical data	Operating voltage (standard)	400 V / 50 Hz	
	Rated connected load	7,2 kW	9,2 kW
	Customer-side back-up fuse	20 A gL/gG	25 A gL/gG
Speeds	Knife shaft	1200/2400 rpm	1500/3000 rpm
	Bowl	9/18 rpm	
Optimum batch sizes boiled/cooked/raw sausage		26,5/23/15 kg	
Weight		550 kg	560 kg

## EQUIPMENT

- machine base with solid stainless steel bearing arm, machine body enclosed on all sides
- bowl lid with protective triangle and hand access protection acc. to EN 12855 standard
- stainless steel bowl
- bowl cleaning run
- noise protection cover
- knife shaft brake, electric
- shaft thermometer
- membrane keyboard
- standard knife head with 6 standard knives, adjusting device

## OPTIONS

- cleaning and transport trolley

## PRECISE TEMPERATURE MEASUREMENT

by entering the values directly in the cutting chamber

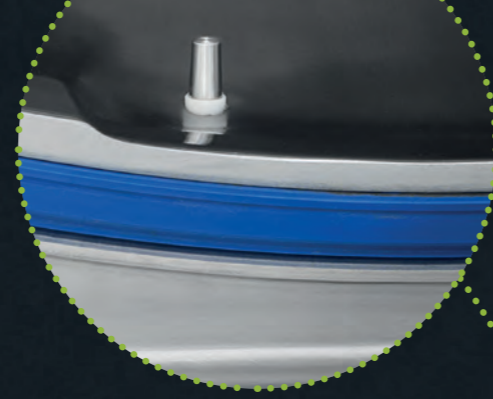

## BOWL CUTTER SM 45 L

Flexible in motion

This bowl cutter also impresses as a specialist device for the perfect cut – and with the clever touch panel, which is integrated into our trade cutters as standard from this size up. Intuitively operable, it ensures easy operability and efficient processes even with small quantities.

## VARIABLE DRIVE

From this cutter size up you also have the following choice: Do you want simple and robust drive technology, or do you set great store by infinitely variable flexibility? With our T2M-R and STL options, you can rely on high-performance functionality and easily maintain a digital overview of product temperature, knife speed, bowl rounds and time.

## DIMENSIONS

Bowl cutter SM 45 L

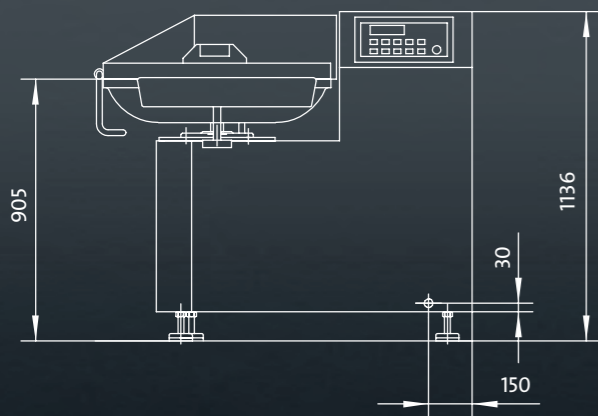

All dimensions in mm

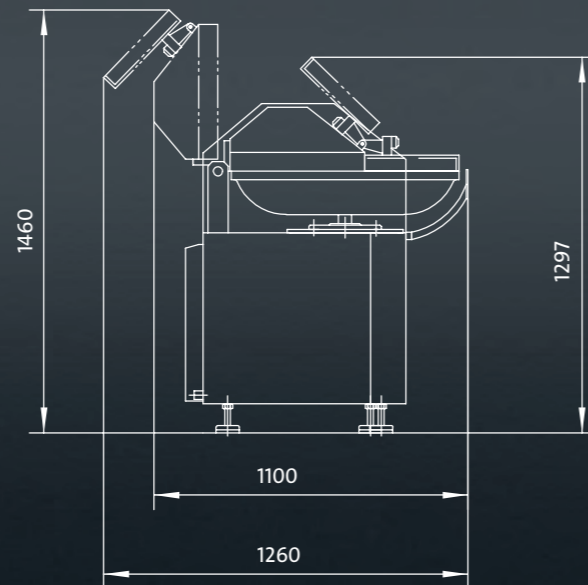

## TOUCHPANEL

ensures intuitive operation and simple control

## TECHNICAL DATA

	SM 45 STL	SM 45 T2M-R		
Type	445			
Version		Standard	reinforced drive	
Electrical data	Operating voltage (standard)	400V / 50 Hz		
	Rated connected load	16 kW	8,9 kW	11,9 kW
	Rated current	35 A	20 A	26 A
	Back-up fuse customer-side	35 A gL/gG	25 A gL/gG	35 A gL/gG
	Leakage current 400 V / 50 Hz typically / maximum at switch-on	34/192 mA		
Speeds	Knife shaft	40–4400 rpm	1200–2400 rpm	1500/3000 rpm 1800/3600 rpm (optional)
	Mixing speed (forward/backward)	40–500 rpm	75/150 rpm	
	Bowl	9/18 rpm		
Optimum batch sizes boiled/cooked/raw sausage	36/32/20 kg			
Weight	770 kg	750 kg	770 kg	

## EQUIPMENT

- machine base with solid stainless steel bearing arm, machine body enclosed on all sides
- bowl lid with protective triangle and hand access protection
- stainless steel bowl
- bowl cleaning run
- noise protection cover
- knife shaft brake electric
- touch screen
- digital display for knife shaft speed, temperature, and bowl revolutions
- temperature, time and bowl revolution stop
- standard knife head with 6 standard knives, adjusting device

## OPTIONS

- time and bowl revolution stop
- cleaning and transport trolley

# BOWL CUTTER TWIN 45 L / D114

Cutter and grinder in one machine

Quality in the smallest space: This is what our bowl cutter twin offers you – the compact multi-talent of the K+G trade cutters. It combines cutter and grinder in one machine and can even be used in small butcher's shops or even ship's kitchens.

## QUICKLY CLEAN AGAIN

The bowl cutter twin is equipped with a 45 l cutter bowl for cutting, mixing and emulsifying – cleverly combined with a 114 mm stuffing grinder. Meat worm and cutting set can be easily removed via a mechanical ejecting device. For maximum efficiency even when cleaning.

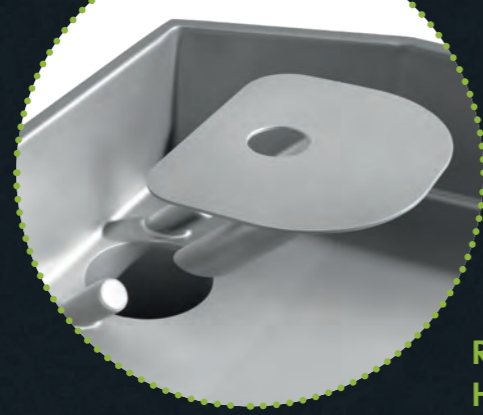

REMOVABLE  
HAND GUARD



## MANUAL SORTING DEVICE

moves hard particles to the side and can be removed or installed without tools

## TECHNICAL DATA

		SM-ZW 45/114 T2M-R (running separately)		SM-ZW 45/114 T2M-R (running simultaneously)	
Type		444			
Version		Standard	reinforced drive	Standard	reinforced drive
Electrical data	Operating voltage (standard)	400 V / 50 Hz			
	Rated connected load	9 kW	12 kW	14,5 kW	17,5 kW
	Customer-side back-up fuse	25 A gL/gG	35 A gL/gG	35 A gL/gG	50 A gL/gG
Speeds	Knife shaft	1200–2400 rpm	1500/3000 rpm 1800/3600 rpm (optional)	1200–2400 rpm	1500/3000 rpm 1800/3600 rpm (optional)
	Mixing speed (forward/reverse)	75/150 rpm			
	Bowl	9/18 rpm			
Meat grinder processing capacity		up to 25 kg/min			
Optimum batch sizes boiled/cooked/raw sausage		36/32/20 kg			
Weight		890 kg	920 kg	890 kg	920 kg

## DIMENSIONS

Bowl cutter twin 45 L / D114

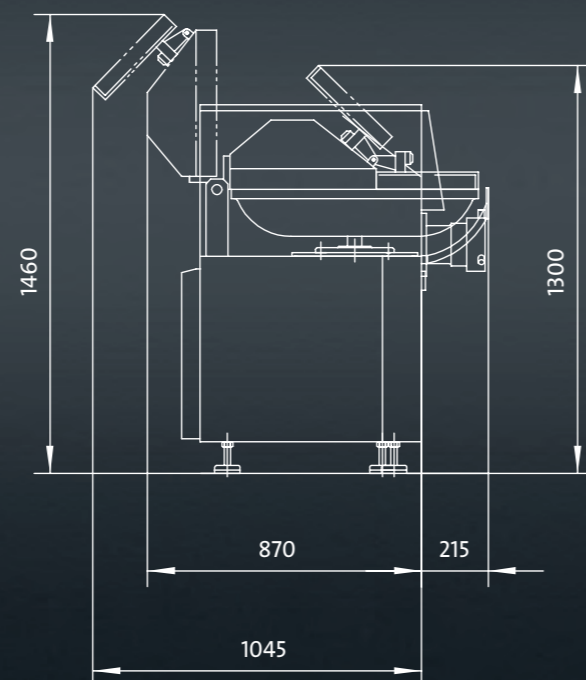
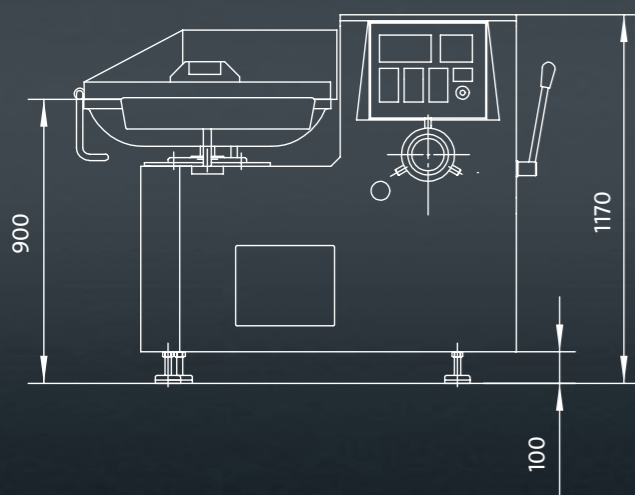

All dimensions in mm

## 1 MACHINE, 2 FUNCTIONS

space-saving cutters and  
grinders in the smallest space

## EQUIPMENT

### BOWL CUTTER

- machine base with solid stainless steel bearing arm, machine body enclosed on all sides
- bowl lid with protective triangle and non-return valve acc. to standard EN 12855
- stainless steel bowl
- bowl cleaning run
- noise protection cover
- knife shaft brake electric
- touch screen
- digital display for knife shaft speed, temperature and bowl revolutions
- temperature, time and bowl revolution stop
- standard knife head with 6 standard knives, adjusting device

### GRINDER PART

- removable hand guard, electrically locked, filling shaft and hand guard according to UVV
- braking device for meat worm drive
- stainless, sealed drive shaft stored in ball bearings
- meat worm and housing of the worm in stainless steel
- stainless steel lock nut
- coded cutting set consisting of: 1 taper tap, 2 knives, with 1 hole plate of 3/5/7.8/13 mm each, 2 spacer rings, stainless steel
- ejecting device for worm and cutting set

## OPTIONS

### BOWL CUTTER

- time and bowl revolution stop

### GRINDER PART

- sorting device manual
- protection cover
- cleaning and transport trolley



**MADE IN GERMANY**

## A GOOD DECISION

Quality pays off

You earn your money with our machines. We are aware of this responsibility – and this can be seen in our high-quality solutions. Well thought-out down to the last detail, they ensure efficient processes and a high degree of security in your company for decades, as well as the certainty that you have made the right choice.

### DROP BY

We would be delighted to show you where and how our cutters, grinders and mixers are made for trade and industry. On a tour of our production facilities in beautiful Hessen, you will get a sense of what has always been driving us at K+G Wetter: The passion of always setting further standards with our ideas. For pure enjoyment – and your success. Worldwide.

Come and see for yourself. We are looking forward to seeing you!

## ALL-ROUND SHARPENING SERVICE

.....  
Directly from the professionals

*If the performance of your cutting tool drops after intensive use, we will restore its sharpness as soon as possible – safe transport included. More information can be found at: [kgwetter.de/schleif-service](http://kgwetter.de/schleif-service)*



K+G WETTER GmbH  
Goldbergstraße 21  
35216 Biedenkopf-Breidenstein

Tel. +49 (0) 64 61 / 98 40 - 0  
Fax +49 (0) 64 61 / 98 40 - 25

info@kgwetter.de  
www.kgwetter.de